

**LAVATORY FAUCET
K-14402**

ADA

Features

- Brass construction
- One-piece, self-contained ceramic disc valve allows both volume and temperature control
- Temperature memory allows faucet to be turned on and off at any temperature setting
- High-temperature limit stop for added safety
- 2.2 gpm (8.3 lpm) flow rate
- Lower flow aerator options are available (refer to the Kohler Price Book)
- Single-hole mounting
- Pop-up drain with lift rod and tailpiece
- Flexible supplies
- Available with straight or curved handle
- 5-1/2" (14 cm) spout

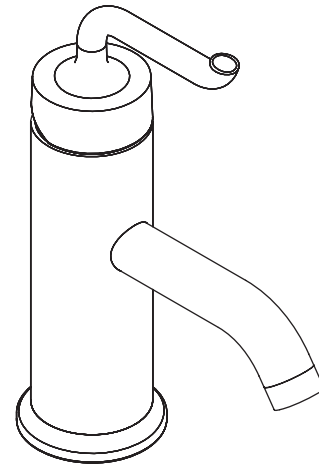

Codes/Standards Applicable

Specified model meets or exceeds the following:

- ASME A112.18.1/CSA B125.1
- IAPMO/UPC
- NSF 61
- ADA

Colors/Finishes

- CP: Polished Chrome
- PB: Polished Brass
- Other: Refer to Price Book for additional colors/finishes

Specified Model

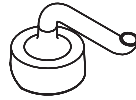
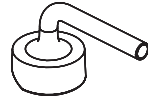
Model	Description		
K-14402-4	With curved handle	<input type="checkbox"/> CP <input type="checkbox"/> PB <input type="checkbox"/> Other ____	
K-14402-4A	With straight handle		<input type="checkbox"/> CP <input type="checkbox"/> PB <input type="checkbox"/> Other ____

Product Specification

Single-control lavatory faucet shall be of brass construction and rated at 2.2 gallons (8.3 L) per minute. Faucet shall have lower flow aerator options. Valve shall be a one-piece, self-contained ceramic disc valve, allowing volume and temperature control. Valve shall feature temperature memory, allowing the faucet to be turned on and off at any temperature setting, and includes a high-temperature limit stop. Faucet shall include single-hole mounting, flexible connections, 5-1/2" (14 cm) spout, pop-up drain with lift rod and tailpiece, and curved or straight handle. Faucet shall be Kohler Model K-14402-_____-_____.

PURIST®

Installation Notes

Install this product according to the installation guide.

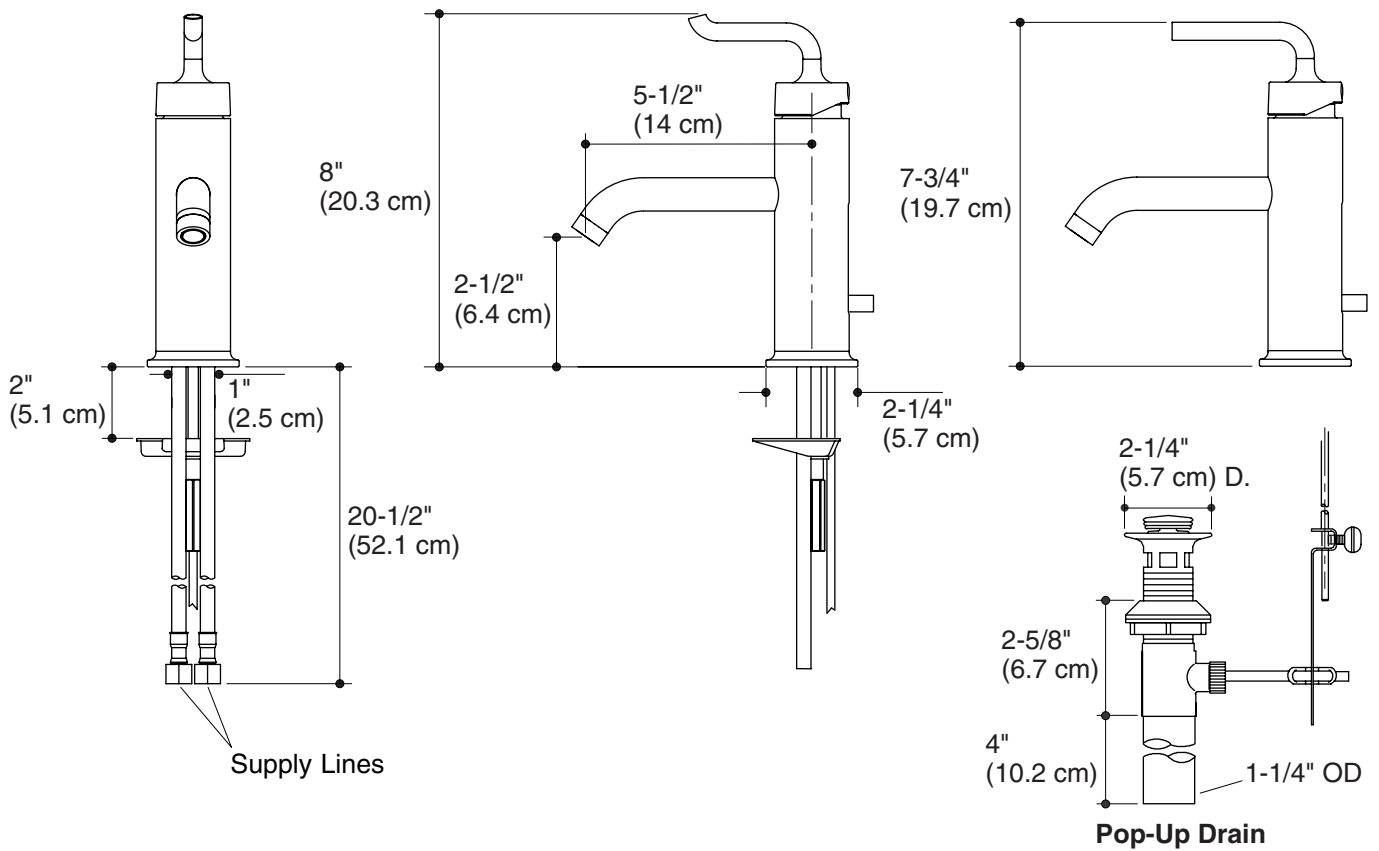

Product Diagram