

# Panasonic

Proprietary Telephones

## Quick Reference Guide

**KX-T7720/KX-T7730**

**KX-T7731/KX-T7735**

Model **KX-T7736/KX-T7750**

### Important Information

#### **When you ship the product:**

Carefully pack and send it prepaid, adequately insured and preferably in the original carton. Attach a postage-paid letter, detailing the symptom to the outside of the carton. DO NOT send the product to the Executive or Regional Sales offices. They are NOT equipped to make repairs.

#### **Product service:**

Panasonic Servicenters for this product are listed in the servicenter directory. Consult your authorized Panasonic dealer for detailed instructions.

#### **WARNING:**

TO PREVENT THE RISK OF FIRE OR ELECTRIC SHOCK, DO NOT EXPOSE THIS PRODUCT TO RAIN OR ANY TYPE OF MOISTURE.

THIS HANDSET EARPIECE IS MAGNETIZED AND MAY RETAIN SMALL FERROUS OBJECTS.

#### **IMPORTANT NOTICE:**

Under power failure conditions, this telephone may not operate. Please ensure that a separate telephone, not dependent on local power, is available for use in an emergency.

#### **Note:**

In this manual, the suffix of each model number is omitted.

#### **Included Accessories: for extra orders, call toll free 1-800-332-5368**

- |   |                            |
|---|----------------------------|
| • Handset . . . . . 1                                 | • Handset Cord . . . . . 1 |
| • Telephone Line Cord . . . . . 1                     | • Stand . . . . . 1        |
| • Overlay . . . . . 1 (Other than KX-T7720, KX-T7750) |                            |

#### **For your future reference**

SERIAL NO. \_\_\_\_\_ DATE OF PURCHASE \_\_\_\_\_  
(found on the bottom of the unit)







NAME OF DEALER \_\_\_\_\_



























DEALER'S ADDRESS \_\_\_\_\_

DEALER'S TEL. NO. \_\_\_\_\_





































**Please read this manual before using and save for future reference.**

# Features List









































 Outside (CO) Line button    
  Programmable Feature button    
  Feature number  
 Off-hook    
  On-hook    
  Talk    
 \* "Location of Controls" is shown on page 8.

Desired Feature	Operation
<b>Making Calls</b>	
Calling	<div style="display: flex; justify-content: space-between;"> <div style="width: 45%;"> <p><b>To an extension</b></p>  ► <span style="border: 1px solid black; padding: 2px;">extension no.</span> ►  </div> <div style="width: 45%; border-left: 1px dashed black; padding-left: 10px;"> <p><b>To an external party</b></p>  ►  ► <span style="border: 1px solid black; padding: 2px;">phone no.</span> ►  </div> </div>
Redial	 ► <span style="border: 1px solid black; border-radius: 10px; padding: 2px;">REDIAL</span> ► 
One-Touch Dialing	<p><b>To program</b></p> <div style="display: flex; align-items: center;"> <div style="margin-right: 10px;">  ►         </div> <div style="border: 1px solid black; padding: 5px; display: flex; align-items: center;"> <div style="margin-right: 10px;">  <span style="border: 1px solid black; padding: 2px;">2</span> /  </div> <div style="margin-right: 10px;"> <span style="border: 1px solid black; padding: 2px;">9</span> <span style="border: 1px solid black; padding: 2px;">9</span> ►  /  ► <span style="border: 1px solid black; padding: 2px;">2</span> </div> <div style="margin-left: 20px;"> <input type="checkbox"/> KX-TA624  <input type="checkbox"/> KX-TA1232         </div> </div> <div style="margin-left: 10px;">►</div> </div> <p style="text-align: center; font-size: small;">(Check the type of your Main Unit.)</p> <div style="display: flex; align-items: center; margin-top: 10px;"> <div style="margin-right: 10px;"> <span style="border: 1px solid black; padding: 2px;">phone no.</span> ►         </div> <div style="margin-right: 10px;">  ►         </div> <div style="margin-right: 10px;">  ►         </div> </div>
	<p><b>To dial</b></p>  ►  /  – assigned as a One-Touch Dialing button ► 
Calling an operator	 ► <span style="border: 1px solid black; padding: 2px;">0</span> ► 
Speed Dialing (Personal)	<p><b>To set</b></p> <div style="display: flex; align-items: center;"> <div style="margin-right: 10px;">  ►         </div> <div style="border: 1px solid black; padding: 5px; display: flex; align-items: center;"> <div style="margin-right: 10px;"> <span style="border: 1px solid black; padding: 2px;">2</span> <span style="border: 1px solid black; padding: 2px;">*</span> <input type="checkbox"/> KX-TA624  <span style="border: 1px solid black; padding: 2px;">3</span> <span style="border: 1px solid black; padding: 2px;">0</span> <input type="checkbox"/> KX-TA1232         </div> </div> <div style="margin-left: 10px;">►</div> </div> <p style="text-align: center; font-size: small;">(Check the type of your Main Unit.)</p> <div style="display: flex; align-items: center; margin-top: 10px;"> <div style="margin-right: 10px;"> <span style="border: 1px solid black; padding: 2px;">desired no.</span> ►         </div> <div style="margin-right: 10px;"> <span style="border: 1px solid black; padding: 2px;">#</span> ►         </div> <div style="margin-right: 10px;">  </div> </div>
	<p><b>To dial</b></p> <div style="display: flex; align-items: center;"> <div style="margin-right: 10px;">  ►         </div> <div style="border: 1px solid black; padding: 5px; display: flex; align-items: center;"> <div style="margin-right: 10px;"> <span style="border: 1px solid black; padding: 2px;">#</span> <input type="checkbox"/> KX-TA624  <span style="border: 1px solid black; padding: 2px;">3</span> <span style="border: 1px solid black; padding: 2px;">*</span> <input type="checkbox"/> KX-TA1232         </div> </div> <div style="margin-left: 10px;">►</div> </div> <p style="text-align: center; font-size: small;">(Check the type of your Main Unit.)</p> <div style="display: flex; align-items: center; margin-top: 10px;"> <div style="margin-right: 10px;"> <span style="border: 1px solid black; padding: 2px;">personal speed dial no.</span> ►         </div> <div style="margin-right: 10px;">  </div> </div>
Speed Dialing (System)	<p><b>To dial</b></p> <div style="display: flex; align-items: center;"> <div style="margin-right: 10px;">  ►         </div> <div style="margin-right: 10px;">  ►         </div> <div style="margin-right: 10px;"> <span style="border: 1px solid black; padding: 2px;">system speed dial no.</span> ►         </div> <div style="margin-right: 10px;">  </div> </div>







# Features List

Desired Feature	Operation				
<b>Receiving Calls</b>					
Handsfree answerback (Other than KX-T7750)	<i>While on-hook</i> 				
Picking up a call	<div style="border: 1px dashed black; padding: 10px;"> <p><b>Outside (CO) Line (KX-TA1232 only)</b></p> <p><b>4</b> <b>*</b></p> <p><b>Directed</b></p> <p>  <span style="margin-left: 20px;"><b>4</b> <b>▶</b> <span style="border: 1px solid black; padding: 2px;">extension no.</span> <input type="checkbox"/> KX-TA624</span>  <span style="margin-left: 20px;"><b>4</b> <b>1</b> <b>▶</b> <span style="border: 1px solid black; padding: 2px;">extension no.</span> <input type="checkbox"/> KX-TA1232</span> </p> <p>(Check the type of your Main Unit.)</p> <p><b>Group</b></p> <p><b>4</b> <b>0</b></p> </div> 				
<b>When the Dialed Extension is Busy/No Answer</b>					
Automatic Callback Busy	<table style="width: 100%; border-collapse: collapse;"> <tr> <td style="width: 50%; vertical-align: top;"> <b>To set</b>  <i>While hearing a busy tone</i>  <b>6</b> <b>▶</b>  </td> <td style="width: 50%; vertical-align: top;"> <b>To call</b>  <i>If you hear callback ringing</i>   </td> </tr> </table>	<b>To set</b> <i>While hearing a busy tone</i> <b>6</b> <b>▶</b> 	<b>To call</b> <i>If you hear callback ringing</i> 		
<b>To set</b> <i>While hearing a busy tone</i> <b>6</b> <b>▶</b> 	<b>To call</b> <i>If you hear callback ringing</i> 				
Message Waiting	<table style="width: 100%;"> <tr> <td style="width: 20%; vertical-align: middle;">Sender</td> <td> <b>To leave a notification</b>            MESSAGE  <b>▶</b>  </td> </tr> <tr> <td></td> <td> <b>To cancel a notification</b>  <div style="border: 1px solid black; padding: 5px; margin: 5px 0;"> <input type="checkbox"/> KX-TA624  <span style="border: 1px solid black; padding: 2px;">receiver's extension no.</span> <b>▶</b> MESSAGE  <b>▶</b> MESSAGE  <b>▶</b>  </div> <div style="border: 1px solid black; padding: 5px; margin: 5px 0;"> <input type="checkbox"/> KX-TA1232  <b>7</b> <b>0</b> <b>0</b> <b>▶</b> <span style="border: 1px solid black; padding: 2px;">receiver's extension no.</span> </div> <p>(Check the type of your Main Unit.)</p> </td> </tr> </table>	Sender	<b>To leave a notification</b> MESSAGE  <b>▶</b> 		<b>To cancel a notification</b> <div style="border: 1px solid black; padding: 5px; margin: 5px 0;"> <input type="checkbox"/> KX-TA624  <span style="border: 1px solid black; padding: 2px;">receiver's extension no.</span> <b>▶</b> MESSAGE  <b>▶</b> MESSAGE  <b>▶</b>  </div> <div style="border: 1px solid black; padding: 5px; margin: 5px 0;"> <input type="checkbox"/> KX-TA1232  <b>7</b> <b>0</b> <b>0</b> <b>▶</b> <span style="border: 1px solid black; padding: 2px;">receiver's extension no.</span> </div> <p>(Check the type of your Main Unit.)</p>
	Sender	<b>To leave a notification</b> MESSAGE  <b>▶</b> 			
	<b>To cancel a notification</b> <div style="border: 1px solid black; padding: 5px; margin: 5px 0;"> <input type="checkbox"/> KX-TA624  <span style="border: 1px solid black; padding: 2px;">receiver's extension no.</span> <b>▶</b> MESSAGE  <b>▶</b> MESSAGE  <b>▶</b>  </div> <div style="border: 1px solid black; padding: 5px; margin: 5px 0;"> <input type="checkbox"/> KX-TA1232  <b>7</b> <b>0</b> <b>0</b> <b>▶</b> <span style="border: 1px solid black; padding: 2px;">receiver's extension no.</span> </div> <p>(Check the type of your Main Unit.)</p>				
<table style="width: 100%;"> <tr> <td style="width: 20%; vertical-align: middle;">Receiver</td> <td> <b>To call back</b>   <b>▶</b> MESSAGE  <b>▶</b>  </td> </tr> <tr> <td></td> <td> <b>To clear all notifications</b>   <b>▶</b> <b>7</b> <b>0</b> <b>0</b> <b>▶</b>  <div style="border: 1px solid black; padding: 5px; margin: 5px 0;"> <span style="border: 1px solid black; padding: 2px;">#</span> <input type="checkbox"/> KX-TA624  <span style="border: 1px solid black; padding: 2px;">your extension no.</span> <input type="checkbox"/> KX-TA1232         </div> <p>(Check the type of your Main Unit.)</p> </td> </tr> </table>	Receiver	<b>To call back</b>  <b>▶</b> MESSAGE  <b>▶</b> 		<b>To clear all notifications</b>  <b>▶</b> <b>7</b> <b>0</b> <b>0</b> <b>▶</b> <div style="border: 1px solid black; padding: 5px; margin: 5px 0;"> <span style="border: 1px solid black; padding: 2px;">#</span> <input type="checkbox"/> KX-TA624  <span style="border: 1px solid black; padding: 2px;">your extension no.</span> <input type="checkbox"/> KX-TA1232         </div> <p>(Check the type of your Main Unit.)</p>	
Receiver	<b>To call back</b>  <b>▶</b> MESSAGE  <b>▶</b> 				
	<b>To clear all notifications</b>  <b>▶</b> <b>7</b> <b>0</b> <b>0</b> <b>▶</b> <div style="border: 1px solid black; padding: 5px; margin: 5px 0;"> <span style="border: 1px solid black; padding: 2px;">#</span> <input type="checkbox"/> KX-TA624  <span style="border: 1px solid black; padding: 2px;">your extension no.</span> <input type="checkbox"/> KX-TA1232         </div> <p>(Check the type of your Main Unit.)</p>				

# Features List

Desired Feature	Operation																																				
<b>When the Dialed Extension is Busy/No Answer</b>																																					
Call Waiting	Sender	<p>While hearing a busy tone</p> <p><b>1</b> ► Wait for an answer. ► </p>																																			
	Receiver	<div style="border: 1px dashed black; padding: 10px; margin-bottom: 10px;"> <input type="checkbox"/> KX-TA624  <b>For outside calls</b>  <table border="0" style="width: 100%;"> <tr> <td style="border: 1px solid black; padding: 2px;"><b>7</b></td> <td style="border: 1px solid black; padding: 2px;"><b>3</b></td> <td style="border: 1px solid black; padding: 2px;"><b>1</b></td> <td style="border: 1px solid black; padding: 2px;"><b>1</b></td> <td style="border: 1px solid black; padding: 2px;"><b>#</b></td> <td>Set</td> </tr> <tr> <td style="border: 1px solid black; padding: 2px;"><b>7</b></td> <td style="border: 1px solid black; padding: 2px;"><b>3</b></td> <td style="border: 1px solid black; padding: 2px;"><b>1</b></td> <td style="border: 1px solid black; padding: 2px;"><b>0</b></td> <td style="border: 1px solid black; padding: 2px;"><b>#</b></td> <td>Cancel</td> </tr> </table> <b>For intercom calls</b>  <table border="0" style="width: 100%;"> <tr> <td style="border: 1px solid black; padding: 2px;"><b>7</b></td> <td style="border: 1px solid black; padding: 2px;"><b>3</b></td> <td style="border: 1px solid black; padding: 2px;"><b>2</b></td> <td style="border: 1px solid black; padding: 2px;"><b>1</b></td> <td style="border: 1px solid black; padding: 2px;"><b>#</b></td> <td>Set</td> </tr> <tr> <td style="border: 1px solid black; padding: 2px;"><b>7</b></td> <td style="border: 1px solid black; padding: 2px;"><b>3</b></td> <td style="border: 1px solid black; padding: 2px;"><b>2</b></td> <td style="border: 1px solid black; padding: 2px;"><b>0</b></td> <td style="border: 1px solid black; padding: 2px;"><b>#</b></td> <td>Cancel</td> </tr> </table> </div> <input type="checkbox"/> KX-TA1232 <table border="0" style="width: 100%;"> <tr> <td style="border: 1px solid black; padding: 2px;"><b>7</b></td> <td style="border: 1px solid black; padding: 2px;"><b>3</b></td> <td style="border: 1px solid black; padding: 2px;"><b>1</b></td> <td style="border: 1px solid black; padding: 2px;"><b>1</b></td> <td>Set</td> </tr> <tr> <td style="border: 1px solid black; padding: 2px;"><b>7</b></td> <td style="border: 1px solid black; padding: 2px;"><b>3</b></td> <td style="border: 1px solid black; padding: 2px;"><b>1</b></td> <td style="border: 1px solid black; padding: 2px;"><b>0</b></td> <td>Cancel</td> </tr> </table> <p>(Check the type of your Main Unit.)</p> <p><b>To talk to the new party</b> While hearing the Call Waiting tone</p> <table border="0" style="width: 100%;"> <tr> <td style="width: 50%; vertical-align: top;"> <b>Terminating a current status</b>   /  ►  </td> <td style="width: 50%; vertical-align: top;"> <b>Holding a current status</b>   ►  /  ►  </td> </tr> </table>	<b>7</b>	<b>3</b>	<b>1</b>	<b>1</b>	<b>#</b>	Set	<b>7</b>	<b>3</b>	<b>1</b>	<b>0</b>	<b>#</b>	Cancel	<b>7</b>	<b>3</b>	<b>2</b>	<b>1</b>	<b>#</b>	Set	<b>7</b>	<b>3</b>	<b>2</b>	<b>0</b>	<b>#</b>	Cancel	<b>7</b>	<b>3</b>	<b>1</b>	<b>1</b>	Set	<b>7</b>	<b>3</b>	<b>1</b>	<b>0</b>	Cancel	<b>Terminating a current status</b>  /  ► 
<b>7</b>	<b>3</b>	<b>1</b>	<b>1</b>	<b>#</b>	Set																																
<b>7</b>	<b>3</b>	<b>1</b>	<b>0</b>	<b>#</b>	Cancel																																
<b>7</b>	<b>3</b>	<b>2</b>	<b>1</b>	<b>#</b>	Set																																
<b>7</b>	<b>3</b>	<b>2</b>	<b>0</b>	<b>#</b>	Cancel																																
<b>7</b>	<b>3</b>	<b>1</b>	<b>1</b>	Set																																	
<b>7</b>	<b>3</b>	<b>1</b>	<b>0</b>	Cancel																																	
<b>Terminating a current status</b>  /  ► 	<b>Holding a current status</b>  ►  /  ► 																																				
<b>During a Conversation</b>																																					
Holding a call	<b>Holding</b>  ► 																																				
	<b>To retrieve a call at the holding extension</b>  ►  /  ► 																																				
Holding a call exclusively	<b>To retrieve an outside call from another extension</b>  ►  ► 																																				
	<b>To retrieve a call on exclusive hold</b>  ►  /  ► 																																				
Transferring a call	<b>Screened</b>  ► <table border="0" style="display: inline-table; vertical-align: middle;"> <tr> <td style="border: 1px solid black; padding: 2px;"><b>extension no.</b></td> <td>To an extension</td> </tr> <tr> <td style="border: 1px solid black; padding: 2px;"> <b>phone no.</b></td> <td>To an external party (System programming is required.)</td> </tr> </table> ► Wait for an answer. ►  ►  Announce.		<b>extension no.</b>	To an extension	 <b>phone no.</b>	To an external party (System programming is required.)																															
	<b>extension no.</b>	To an extension																																			
 <b>phone no.</b>	To an external party (System programming is required.)																																				
<b>Unscreened to an extension</b>  ► <table border="0" style="display: inline-table; vertical-align: middle;"> <tr> <td style="border: 1px solid black; padding: 2px;"><b>extension no.</b></td> <td>► </td> </tr> </table>		<b>extension no.</b>	► 																																		
<b>extension no.</b>	► 																																				

# Features List

Desired Feature	Operation
<b>Useful Features</b>	
Paging	<p><b>To page</b></p> <div style="border: 1px dashed black; padding: 5px;"> <p><b>All extensions</b>  <input type="text" value="3"/> <input type="text" value="3"/> <input type="text" value="0"/></p> <p><b>Group</b>  <input type="text" value="3"/> <input type="text" value="3"/> ▶ <input type="text" value="group no."/></p> <p><input type="checkbox"/> KX-TA624</p> <p><b>All external speakers</b>  <input type="text" value="3"/> <input type="text" value="4"/></p> <p><b>All extensions &amp; external speakers</b>  <input type="text" value="3"/> <input type="text" value="3"/> <input type="text" value="*"/></p> <p><input type="checkbox"/> KX-TA1232</p> <p><b>All external speakers</b>  <input type="text" value="3"/> <input type="text" value="2"/> <input type="text" value="0"/></p> <p><b>Specific external speaker</b>  <input type="text" value="3"/> <input type="text" value="2"/> ▶ <input type="text" value="external speaker no."/></p> <p><b>All extensions &amp; external speakers</b>  <input type="text" value="3"/> <input type="text" value="3"/> <input type="text" value="*"/></p> <p>(Check the type of your Main Unit.)</p> </div> <p>▶  Announce.</p> <p><b>To answer an announced page</b></p> <div style="border: 1px dashed black; padding: 5px;"> <p><b>From a telephone speaker</b>  <input type="text" value="4"/> <input type="text" value="3"/></p> <p><b>From an external speaker</b>  <input type="text" value="4"/> <input type="text" value="3"/> <input type="checkbox"/> KX-TA624  <input type="text" value="4"/> <input type="text" value="2"/> ▶ <input type="text" value="external speaker no."/> <input type="checkbox"/> KX-TA1232</p> <p>(Check the type of your Main Unit.)</p> </div> <p>▶ </p>
Three-party conference	<p> <sup>CONF</sup> <input type="text" value="U"/> ▶ <input type="text" value="third party's no."/> ▶  ▶ <sup>CONF</sup> <input type="text" value="U"/> </p>
Setting Absent Message	<p><b>To set</b></p> <div style="border: 1px dashed black; padding: 5px;"> <p><input type="checkbox"/> KX-TA624  <input type="text" value="7"/> <input type="text" value="5"/> ▶ <input type="text" value="message no."/> ▶ <input type="text" value="parameter (if required)"/> ▶ <input type="text" value="#"/></p> <p><input type="checkbox"/> KX-TA1232  <input type="text" value="7"/> <input type="text" value="5"/> <input type="text" value="0"/> ▶ <input type="text" value="message no."/> ▶ <input type="text" value="parameter (if required)"/></p> <p>(Check the type of your Main Unit.)</p> </div> <p>▶ </p> <p><b>To cancel</b></p> <div style="border: 1px dashed black; padding: 5px;"> <p><input type="text" value="7"/> <input type="text" value="5"/> <input type="text" value="0"/> <input type="text" value="#"/> <input type="checkbox"/> KX-TA624</p> <p><input type="text" value="7"/> <input type="text" value="5"/> <input type="text" value="0"/> <input type="text" value="0"/> <input type="checkbox"/> KX-TA1232</p> <p>(Check the type of your Main Unit.)</p> </div> <p>▶ </p>

# Features List

Desired Feature	Operation
<b>Useful Features</b>	
Log-In/Log-Out	<div style="border: 1px dashed black; padding: 10px;"> <input type="checkbox"/> KX-TA624  <div style="display: flex; align-items: center; margin-bottom: 10px;"> <span style="border: 1px solid black; padding: 2px 5px; margin-right: 5px;">7</span> <span style="border: 1px solid black; padding: 2px 5px; margin-right: 5px;">3</span> <span style="border: 1px solid black; padding: 2px 5px; margin-right: 5px;">6</span> <span style="border: 1px solid black; padding: 2px 5px; margin-right: 5px;">0</span> <span style="border: 1px solid black; padding: 2px 5px; margin-right: 5px;">#</span> <span style="margin-left: 10px;">For Log-In</span> </div> <div style="display: flex; align-items: center; margin-bottom: 10px;"> <span style="border: 1px solid black; padding: 2px 5px; margin-right: 5px;">7</span> <span style="border: 1px solid black; padding: 2px 5px; margin-right: 5px;">3</span> <span style="border: 1px solid black; padding: 2px 5px; margin-right: 5px;">6</span> <span style="border: 1px solid black; padding: 2px 5px; margin-right: 5px;">1</span> <span style="border: 1px solid black; padding: 2px 5px; margin-right: 5px;">#</span> <span style="margin-left: 10px;">For Log-Out</span> </div> <input type="checkbox"/> KX-TA1232  <div style="display: flex; align-items: center; margin-bottom: 10px;"> <span style="border: 1px solid black; padding: 2px 5px; margin-right: 5px;">4</span> <span style="border: 1px solid black; padding: 2px 5px; margin-right: 5px;">5</span> <span style="border: 1px solid black; padding: 2px 5px; margin-right: 5px;">1</span> <span style="margin-left: 10px;">For Log-In</span> </div> <div style="display: flex; align-items: center; margin-bottom: 10px;"> <span style="border: 1px solid black; padding: 2px 5px; margin-right: 5px;">4</span> <span style="border: 1px solid black; padding: 2px 5px; margin-right: 5px;">5</span> <span style="border: 1px solid black; padding: 2px 5px; margin-right: 5px;">0</span> <span style="margin-left: 10px;">For Log-Out</span> </div> <p style="font-size: small;">(Check the type of your Main Unit.)</p> </div>
Forwarding a call	<div style="border: 1px dashed black; padding: 10px;"> <input type="checkbox"/> KX-TA624  <div style="margin-bottom: 10px;"> <b>All calls</b>  <span style="border: 1px solid black; padding: 2px 5px; margin-right: 5px;">1</span> ▶ extension no. ▶ <span style="border: 1px solid black; padding: 2px 5px; margin-right: 5px;">#</span> </div> <div style="margin-bottom: 10px;"> <b>Busy/No answer</b>  <span style="border: 1px solid black; padding: 2px 5px; margin-right: 5px;">2</span> ▶ extension no. ▶ <span style="border: 1px solid black; padding: 2px 5px; margin-right: 5px;">#</span> </div> <div style="margin-bottom: 10px;"> <b>To an outside line</b>  <span style="border: 1px solid black; padding: 2px 5px; margin-right: 5px;">3</span> ▶ line access code ▶ phone no. ▶ <span style="border: 1px solid black; padding: 2px 5px; margin-right: 5px;">#</span> </div> <div style="margin-bottom: 10px;"> <b>Follow Me</b>  <span style="border: 1px solid black; padding: 2px 5px; margin-right: 5px;">5</span> ▶ your extension no. ▶ <span style="border: 1px solid black; padding: 2px 5px; margin-right: 5px;">#</span> </div> <div style="margin-bottom: 10px;"> <b>Cancel Follow Me</b>  <span style="border: 1px solid black; padding: 2px 5px; margin-right: 5px;">8</span> ▶ your extension no. ▶ <span style="border: 1px solid black; padding: 2px 5px; margin-right: 5px;">#</span> </div> <div style="margin-bottom: 10px;"> <b>Cancel</b>  <span style="border: 1px solid black; padding: 2px 5px; margin-right: 5px;">0</span> ▶ <span style="border: 1px solid black; padding: 2px 5px; margin-right: 5px;">#</span> </div> <input type="checkbox"/> KX-TA1232  <div style="margin-bottom: 10px;"> <b>All calls</b>  <span style="border: 1px solid black; padding: 2px 5px; margin-right: 5px;">2</span> ▶ extension no.         </div> <div style="margin-bottom: 10px;"> <b>Busy</b>  <span style="border: 1px solid black; padding: 2px 5px; margin-right: 5px;">3</span> ▶ extension no.         </div> <div style="margin-bottom: 10px;"> <b>No answer</b>  <span style="border: 1px solid black; padding: 2px 5px; margin-right: 5px;">4</span> ▶ extension no.         </div> <div style="margin-bottom: 10px;"> <b>Busy/No answer</b>  <span style="border: 1px solid black; padding: 2px 5px; margin-right: 5px;">5</span> ▶ extension no.         </div> <div style="margin-bottom: 10px;"> <b>To an outside line</b>  <span style="border: 1px solid black; padding: 2px 5px; margin-right: 5px;">6</span> ▶ line access code ▶ phone no. ▶ <span style="border: 1px solid black; padding: 2px 5px; margin-right: 5px;">#</span> </div> <div style="margin-bottom: 10px;"> <b>Follow Me</b>  <span style="border: 1px solid black; padding: 2px 5px; margin-right: 5px;">7</span> ▶ your extension no.         </div> <div style="margin-bottom: 10px;"> <b>Cancel Follow Me</b>  <span style="border: 1px solid black; padding: 2px 5px; margin-right: 5px;">8</span> ▶ your extension no.         </div> <div style="margin-bottom: 10px;"> <b>Cancel</b>  <span style="border: 1px solid black; padding: 2px 5px; margin-right: 5px;">0</span> </div> <p style="font-size: small;">(Check the type of your Main Unit.)</p> </div>

# Features List

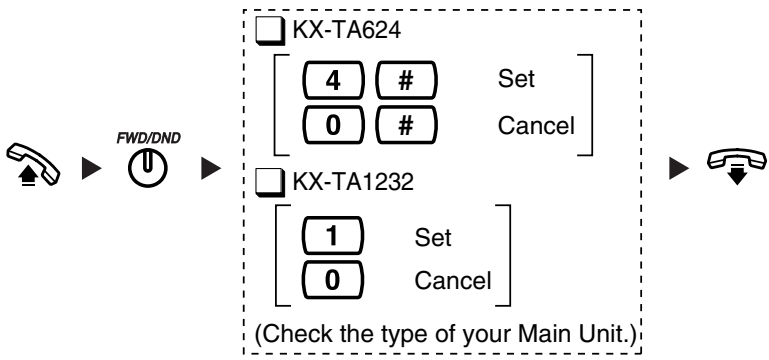
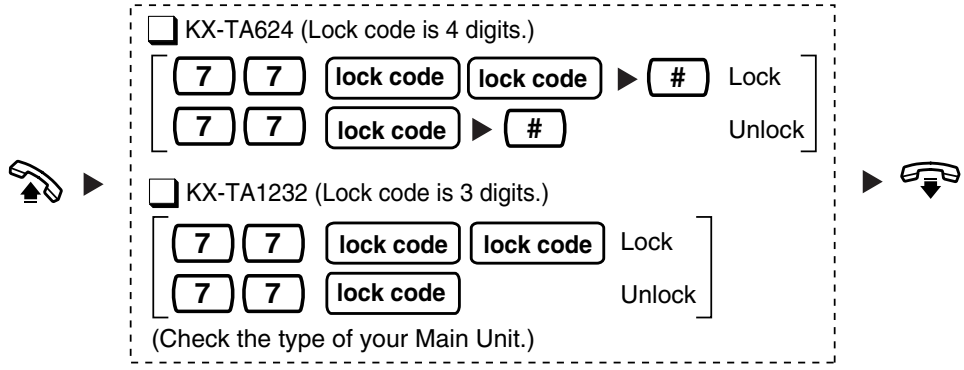
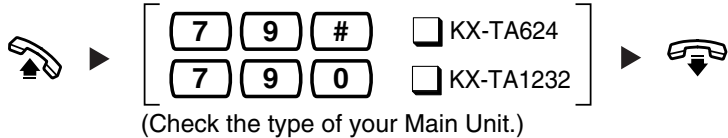
Desired Feature	Operation
<b>Useful Features</b>	
Do Not Disturb (DND)	 <p> <input type="checkbox"/> KX-TA624            [ 4 # Set              0 # Cancel ]  <input type="checkbox"/> KX-TA1232            [ 1 Set              0 Cancel ]            (Check the type of your Main Unit.)         </p>
Locking your extension	 <p> <input type="checkbox"/> KX-TA624 (Lock code is 4 digits.)            [ 7 7 lock code lock code # Lock              7 7 lock code # Unlock ]  <input type="checkbox"/> KX-TA1232 (Lock code is 3 digits.)            [ 7 7 lock code lock code Lock              7 7 lock code Unlock ]            (Check the type of your Main Unit.)         </p>
Clearing the setting	 <p>           [ 7 9 # <input type="checkbox"/> KX-TA624              7 9 0 <input type="checkbox"/> KX-TA1232 ]            (Check the type of your Main Unit.)         </p>

\* Consult your dealer for more details on the operations above.

# Location of Controls

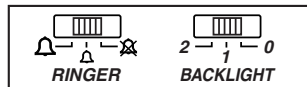

**RINGER Volume Selector/  
BACKLIGHT  
Illumination Selector**

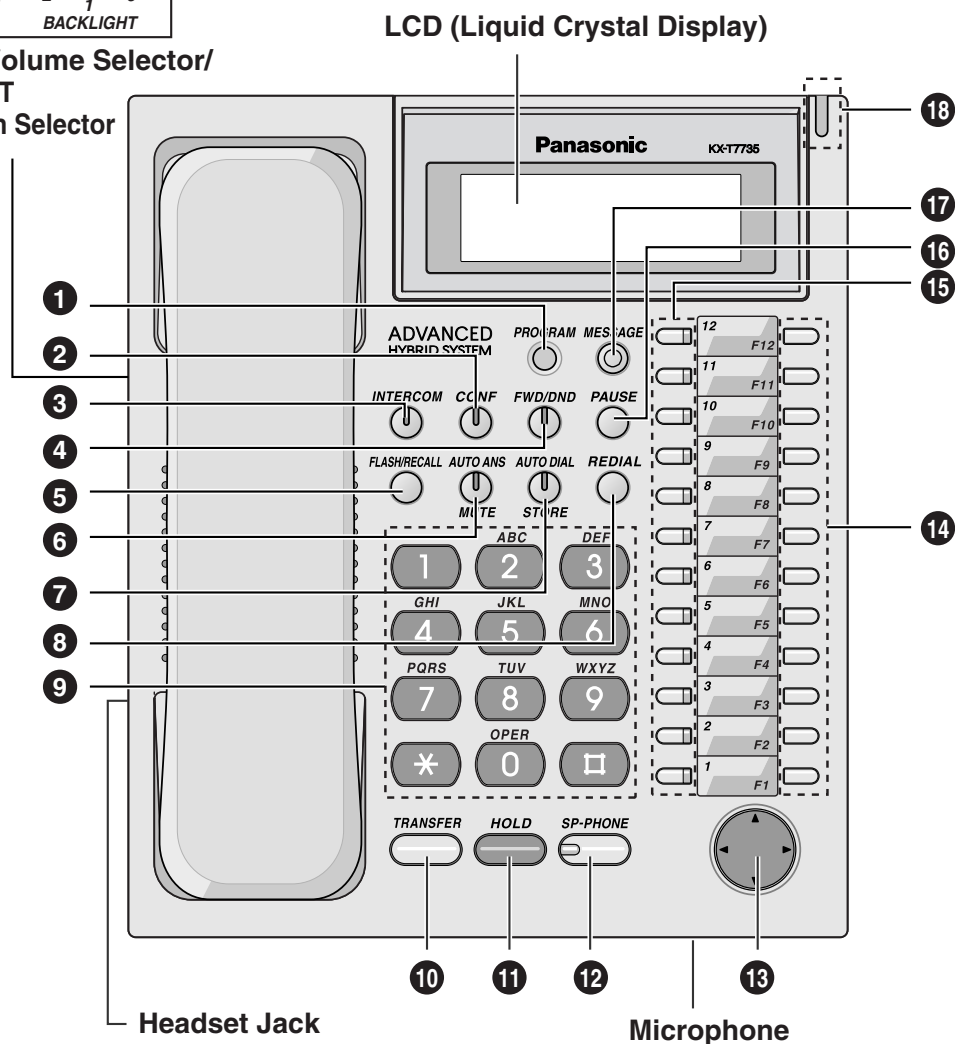

- \* The KX-T7750 does not have a microphone.
- \* The backlit display is only available on the KX-T7730/7731/7735/7736.
- \* The headset is an option. Recommended headsets are KX-TCA91 and KX-TCA92.

- 1 PROGRAM:** Used to enter and exit the programming mode.
- 2 CONF (Conference):** Used to establish a multiple party conversation.
- 3 INTERCOM:** Used to make or receive intercom calls.
- 4 FWD/DND (Call Forwarding/Do Not Disturb):** Used to perform Call Forwarding or Do Not Disturb.
- 5 FLASH/RECALL:** Used for External Feature Access or to disconnect the current call and make another call without hanging up.
- 6 AUTO ANS (Auto Answer) (Other than KX-T7750):** Used to receive an incoming call in the hands-free mode.
- MUTE (Other than KX-T7750):** Used to mute the microphone during a conversation.
- VOICE CALL (KX-T7750 only):** Used to receive a notification via monitor in place of ringing.
- 7 AUTO DIAL/STORE:** Used for speed dialing or storing program changes.
- 8 REDIAL:** Used to redial.



# Location of Controls

- 9 DIALING BUTTONS WITH BACKLIGHT (KX-T7731/36):** Dialing buttons are backlit when (1) you receive a call, (2) during a conversation, or (3) when BGM is activated at your phone.
- 10 TRANSFER:** Used to transfer a call to another party.
- 11 HOLD:** Used to place a call on hold.
- 12 SP-PHONE (Other than KX-T7750):** Used for the handsfree operation.

**MONITOR (KX-T7750 only):** Used for handsfree dialing. You can monitor the other party's voice handsfree.
- 13 NAVIGATOR KEY (KX-T7730/7731/7735/7736):** Used to adjust the volume and the display contrast, or select desired items.

**VOLUME KEY (KX-T7720/7750):** Used to adjust the volume.
- 14 Programmable Feature (PF) Button:** Used as an One-Touch Dialing button (Button assignment is required).
- 15 Flexible Outside (CO) Line Button:** Used to make or receive an outside call. Pressing this button seizes an idle outside line automatically. (Button assignment is required.) Also used as feature buttons. (Button assignment is required.)
- 16 PAUSE:** Used to insert a pause during dialing.
- 17 MESSAGE:** Used to leave a message waiting indication, or call back the party who left the message waiting indication.
- 18 Message/Ringer Lamp:** The Message/Ringer lamp informs you visually that you have a message or a call.

  - When you receive a call, the lamp flashes depending on the ringing pattern. When the ringing pattern is set to Single (Slow flash), Double (Moderate flash), or Triple (Rapid flash) in your PBX, the lamp flashes. When the other ringing patterns are set in your PBX, the lamp may not flash. (e.g., S-Double, Call Waiting Tone1).
  - When someone has left you a message, the lamp is lit continuously.

# Initial Settings

## ◆ Speaker volume \*

While on-hook or during a conversation



Press **SP-PHONE**. Press **Up** or **Down**.

## ◆ Handset/Headset volume \*

While using the handset or headset



Press **Up** or **Down**.

## ◆ Ringer volume/Backlight illumination



Slide the lever of the **RINGER** Volume Selector and **BACKLIGHT** Illumination Selector to the desired setting.

BACKLIGHT SW POSITION	2	1	0
LCD backlight	HIGH	LOW	OFF
DIALING BUTTONS backlight	AUTO	AUTO	OFF

AUTO: The backlight shines only during operation.

## ◆ Display contrast \*

**KX-T7730/7731/7735/7736**



Press **Left** or **Right**.

\* The above settings may return to default settings if the telephone line cord is disconnected, or the main unit's power is interrupted.

# Connection

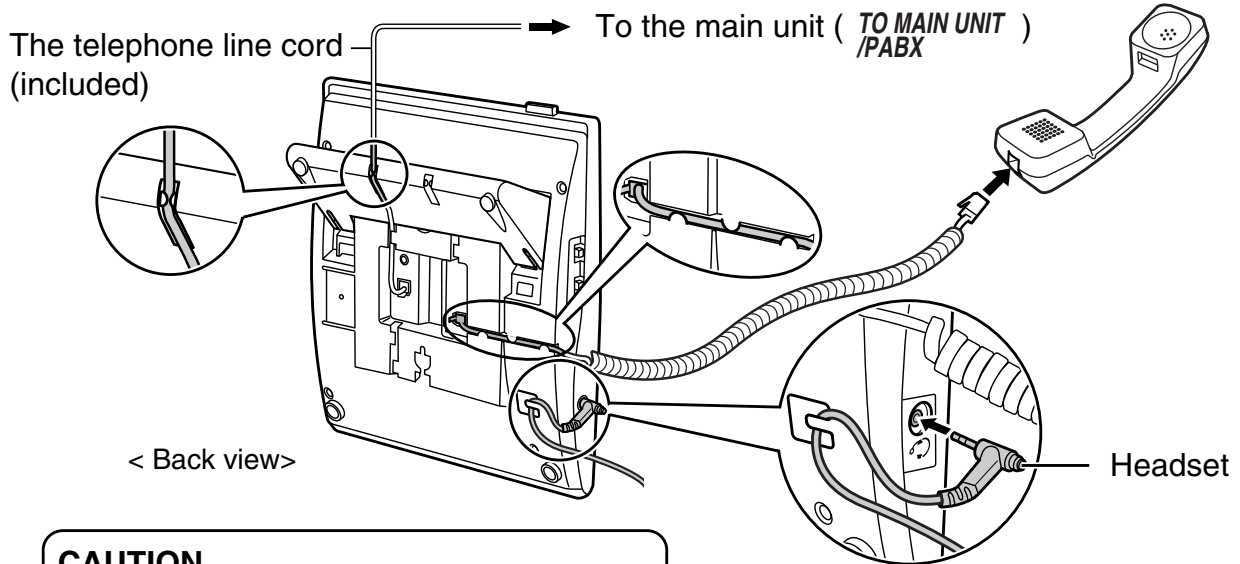

## CAUTION

Ensure the cord is inserted in the groove to prevent damage to the connector.

# Wall Mounting

1 Pull down the handset hook until it locks, so the tab holds the handset.

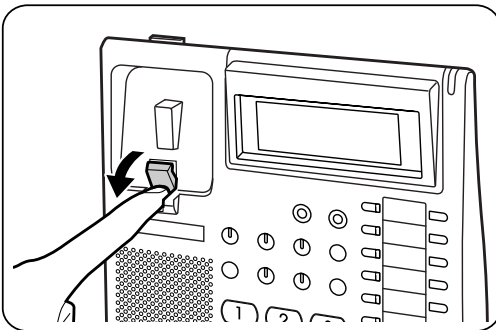

2 Remove the attached stand.

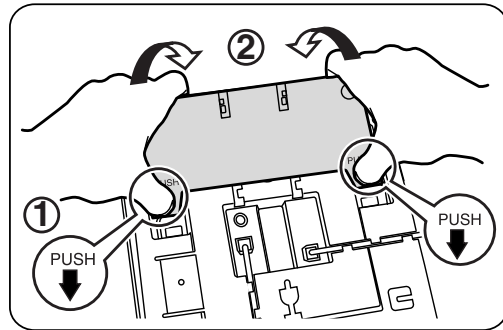

3 Mount the unit on the wall.

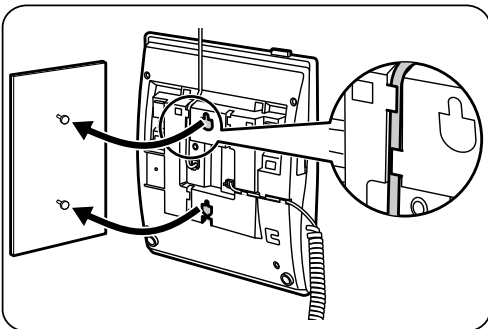

To temporarily place the handset down during a conversation, hook it over the top edge of the phone as shown.

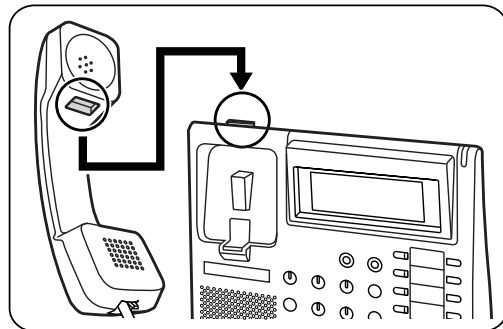

\* KX-T7735 model illustrated on this page.

# ***Exhibit J - Customer Information***

---

This equipment complies with Part 68 of the ACTA rules and the requirements adopted by the ACTA. On the exterior of the cabinet of this equipment is a label that contains, among other information, a product identifier in the format ACJGTB-32973-MF-E/ACJGTB-43121-MF-E. If requested, this number must be provided to the telephone company.

- ACTA Registration Number (KX-TA624): ACJGTB-32973-MF-E  
(KX-TA1232): ACJGTB-43121-MF-E
- Ringer Equivalence Number (REN): 0.4B
- Facility Interface Code (FIC): 02LS2
- Service Order Code (SOC): 9.0F
- USOC Jack Type (KX-TA624): RJ11  
(KX-TA1232): RJ11 and RJ14C

A FCC compliant telephone cord and modular plug is provided with this equipment. This equipment is designed to be connected to the telephone network or premises wiring using a compatible modular jack that is Part 68 compliant. See Installation Instructions for details.

If this equipment KX-T7731/36 causes harm to the telephone network, the telephone company will notify you in advance that temporary discontinuance of service may be required. But if advance notice isn't practical, the telephone company will notify the customer as soon as possible. Also, you will be advised of your right to file a complaint with the FCC if you believe it is necessary.

The telephone company may make changes to its facilities, equipment, operations or procedures that could affect the operation of the equipment. If this happens the telephone company will provide advance notice so you can make the necessary modifications to maintain uninterrupted service.

If trouble is experienced with this equipment KX-T7731/36, for repair or warranty information, please contact

**Panasonic Services Company**  
**BTS Center**  
**1225 Northbrook Parkway Suite**  
**1-216 Suwanee**  
**GA 30024**

If the equipment is causing harm to the telephone network, the telephone company may request that you disconnect the equipment until the problem is resolved.

Connection to party line service is subject to state tariffs. (Contact the state public utility commission, public service commission or corporation commission for information.)

This equipment is hearing aid compatible.

# Exhibit J - Customer Information

---

## Data Equipment

The table below shows which jacks are associated with which modes of operation:

Mode of Operation	USOC Jack	
	KX-TA624	KX-TA1232
Permissive	RJ11	RJ11 and RJ14C
Programmable	RJ41S and RJ45S	RJ41S and RJ45S
Fixed Loss Loop	RJ41S	RJ41S

## Systems

Facility Interface Codes (FIC), Service Order Codes (SOC), USOC Jack Codes and Ringer Equivalence Numbers (REN) are shown in the table below for each port where applicable:

Port	FIC	SOC	USOC Jack		Port
			KX-TA624	KX-TA1232	
CO1 ~ 3	02LS2	9.0F	RJ11	RJ11 and RJ14C	0.4B

## Adjuncts – KX and PX Devices

When this adjunct is used with a leased system, permission of the owner should be requested for connection of the adjunct.

KX-type telephones with message waiting lights and/or line status indicators can only be connected to host equipment and never directly to the network.

KX devices can only be installed with the permission of the owner of the host equipment as “surgery” is often required on the host system.

# ***Important Safety Instructions***

---

When using this unit, basic safety precautions should always be followed to reduce the risk of fire, electric shock, or personal injury.

1. Read and understand all instructions.
2. Follow all warnings and instructions marked on this unit.
3. Unplug this unit from the main unit before cleaning. Do not use liquid or aerosol cleaners. Use a damp cloth for cleaning.
4. Do not use this unit near water, for example, near a bathtub, washbowl, kitchen sink, or the like.
5. Place this unit securely on a stable surface. Serious damage and/or injury may result if the unit falls.
6. Do not cover slots and openings on the unit. They are provided for ventilation and protection against overheating. Never place the unit near radiators, or in a place where proper ventilation is not provided.
7. Do not allow anything to rest on the extension cord. Do not locate this unit where the cord will be abused by persons walking on it.
8. Do not overload wall outlets and extension cords. This can result in the risk of fire or electric shock.
9. Never push any objects through slots in this unit. This may result in the risk of fire or electric shock. Never spill any liquid on the unit.
10. To reduce the risk of electric shock, do not disassemble this unit. Take the unit to an authorized servicer when service is required. Opening or removing covers may expose you to dangerous voltages or other risks. Incorrect reassembly can cause electric shock when the unit is subsequently used.
11. Unplug this unit from the main unit, and refer servicing to an authorized servicer when the following conditions occur:
  - A. When the extension cord is damaged or frayed.
  - B. If liquid has been spilled into the unit.
  - C. If the unit has been exposed to rain or water.
  - D. If the unit does not work normally by following the manual. Adjust only controls covered by the manual. Improper adjustment may require extensive work by an authorized servicer.
  - E. If the unit has been dropped, or physically damaged.
  - F. If the unit exhibits a distinct change in performance.
12. Avoid using a telephone (other than a cordless type) during an electrical storm. There may be a remote risk of electric shock from lightning.
13. Do not use this unit to report a gas leak, when in the vicinity of the leak.

**SAVE THESE  
INSTRUCTIONS**

# ***FCC and Other Information***

---

**NOTE:** This equipment has been tested and found to comply with the limits for a Class B digital device, pursuant to Part 15 of the FCC Rules. These limits are designed to provide reasonable protection against harmful interference in a residential installation. This equipment generates, uses and can radiate radio frequency energy and, if not installed and used in accordance with the instructions, may cause harmful interference to radio communications. However, there is no guarantee that interference will not occur in a particular installation. If this equipment does cause harmful interference to radio or television reception, which can be determined by turning the equipment off and on, the user is encouraged to try to correct the interference by one or more of the following measures:

- Reorient or relocate the receiving antenna.
- Increase the separation between the equipment and receiver.
- Connect the equipment into an outlet on a circuit different from that to which the receiver is connected.
- Consult the dealer or an experienced radio/TV technician for help.

**CAUTION:** To assure continued compliance with FCC rules, do not make any unauthorized modifications. When programming emergency numbers and/or making test calls to emergency numbers:

- 1) Remain on the line and briefly explain to the dispatcher the reason for the call before hanging up.
  - 2) Perform such activities in the off peak hours, such as early morning hours or late evenings.
- If there is any problem, unplug the extension and connect a known working phone. If the known working phone operates properly, have the defective phone repaired by your maintainer. If the known working phone does not operate properly, check the PBX System and the internal extension wiring.
  - Keep the unit away from heating appliances and electrical noise generating devices such as fluorescent lamps and motors.
  - The unit should be kept free of dust, moisture and vibration, and should not be exposed to direct sunlight.
  - Do not use benzine, thinner, or any abrasive powder to clean the cabinet. Wipe it with a soft cloth.
  - Do not disassemble this unit. Dangerous electrical shock could result. The unit must only be disassembled and repaired by qualified service technicians. When a failure occurs which exposes any internal parts, disconnect the telephone line and mains supply immediately and return the unit to your maintainer.

**This telephone provides magnetic coupling for hearing aids.**



**Panasonic Consumer Electronics  
Company, Division of Matsushita  
Electric Corporation of America**  
One Panasonic Way,  
Secaucus, New Jersey 07094  
[www.panasonic.com](http://www.panasonic.com)

**Panasonic Sales Company ("PSC"),  
Division of Matsushita Electric of  
Puerto Rico, Inc.**  
Ave. 65 de Infantería, Km. 9.5,  
San Gabriel Industrial Park, Carolina,  
Puerto Rico 00985

© 2002 Panasonic Communications Co., Ltd. All Rights Reserved.